

TOP SLAB PLAN VIEW

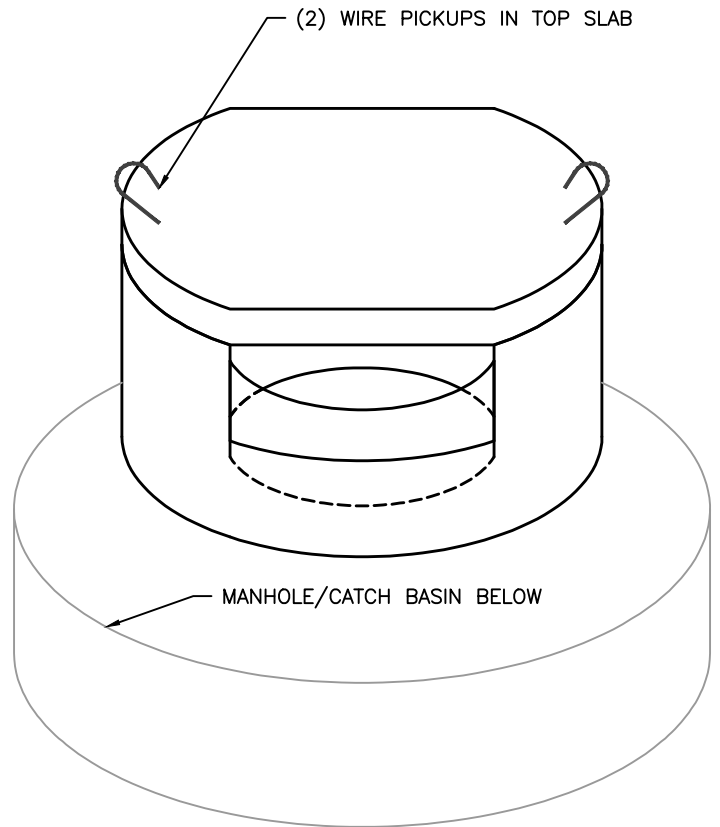

ISOMETRIC VIEW

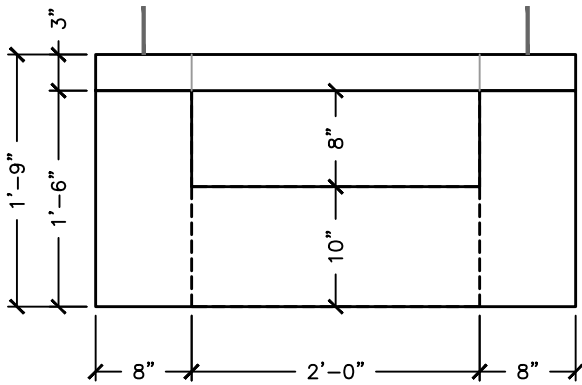

TOP SLAB PLAN VIEW

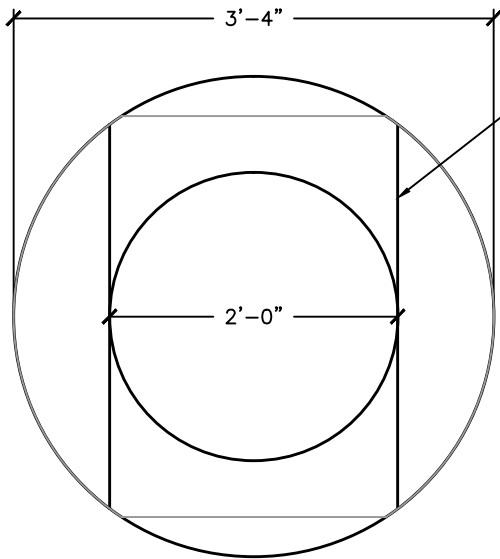

BASE SECTION VIEW

180 DEGREE DOUBLE THROAT SHOWN.
ALTERNATE ANGLES OR SINGLE
THROAT AVAILABLE UPON REQUEST

NOTES:

1. CONCRETE: 4,000 PSI MINIMUM @ 28 DAYS, PER ASTM C-478 (6.1). CEMENT TO BE PER ASTM C-150.
2. TOP SLAB 0.11CY (450#) BASE SECTION 0.33CY (1400#)

Revised: 7/22/14

DWG NO.
S1

Customer:

Project Name:
Project Location:

NHDOT CATCH BASIN
TYPE "C" THROAT

Project No:

Scale: AS SHOWN

Date:

Designed by:

Drawn by: PFL

Checked by: XXX



173 BUXTON INDUSTRIAL DRIVE-PO BOX 870
HENNIKER, NH 03242
PHONE: 603-428-3218
FAX: 603-428-7426
www.michiecorp.com